

Recovery Improvement

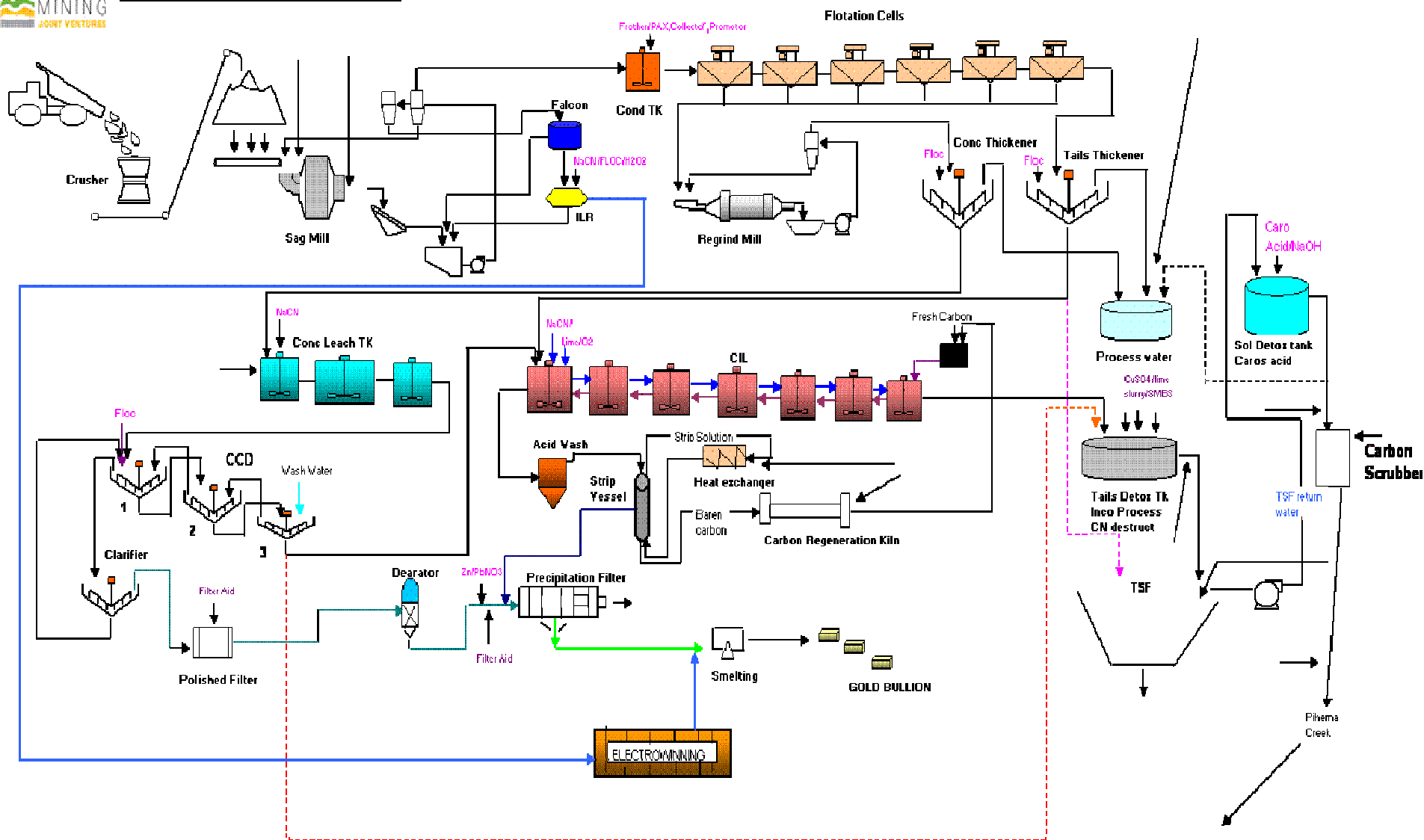

MMJV SIMPLIFIED PROCESS FLOW SHEET



Hidden Valley Improvement

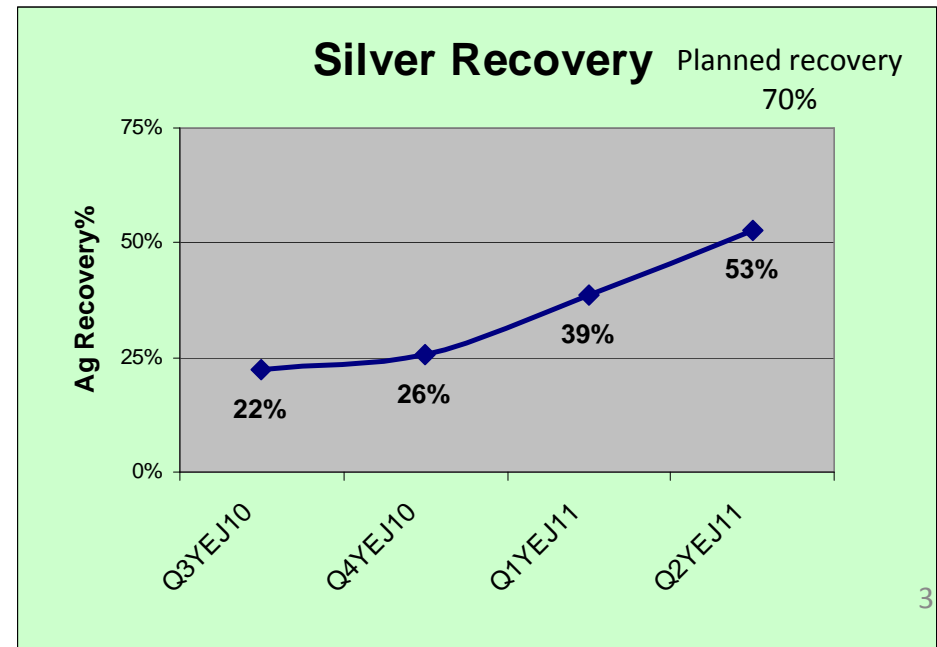
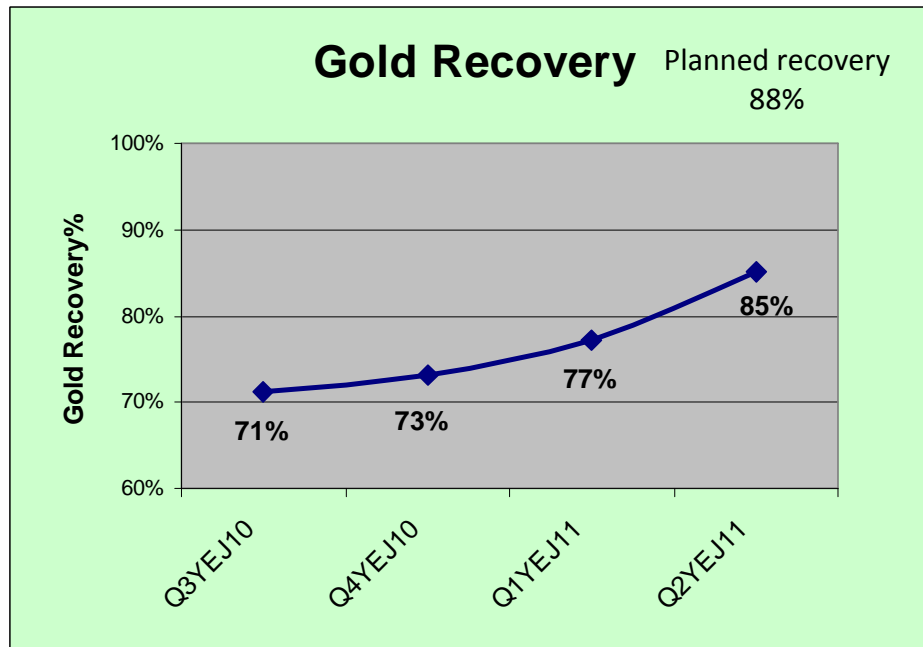

Recovery Improvement

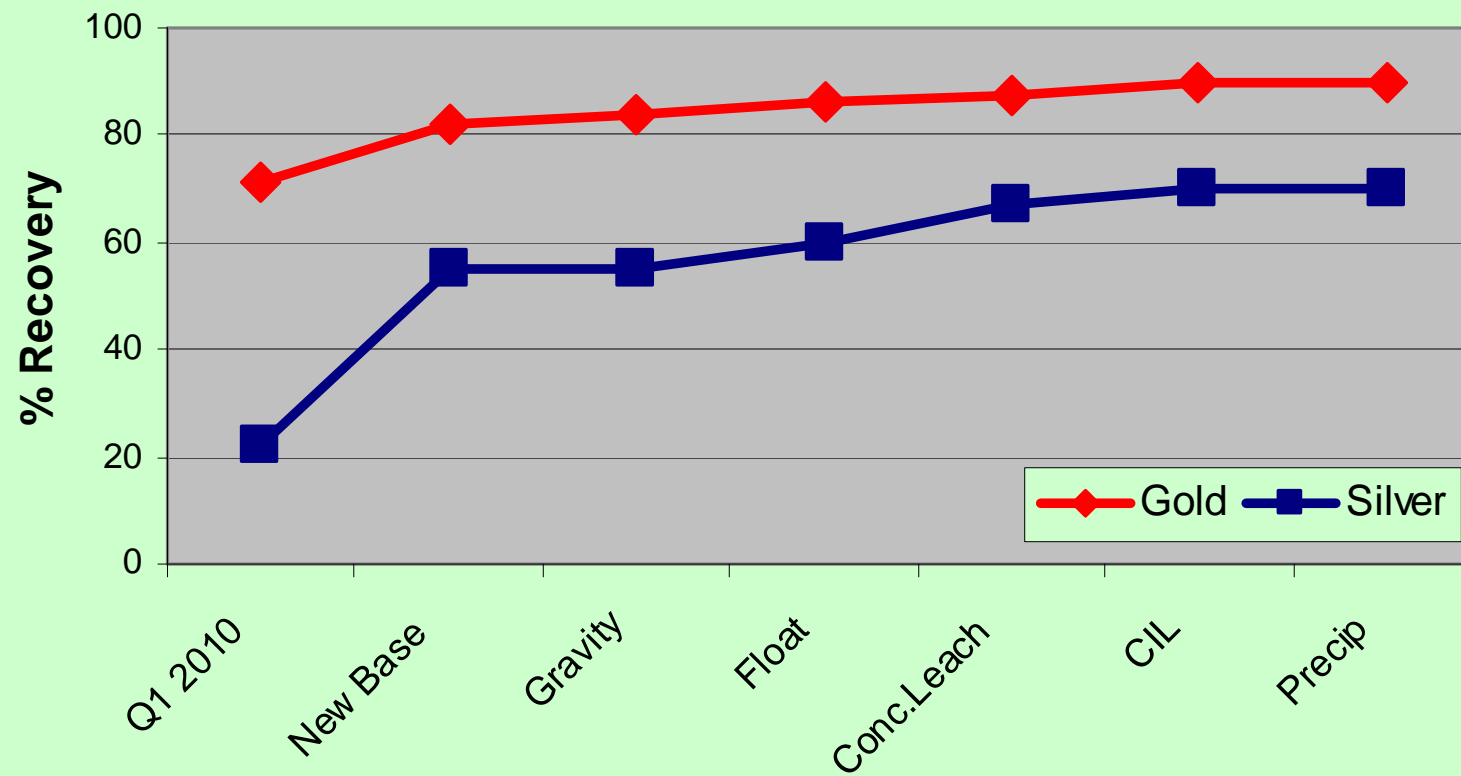

- What did we do?
 - Training. Specialist training and met support
 - Flotation testing. Improved reagent scheme, optimised mass pull.
 - Automate pH control in CIL and con leach
 - Leach testing, improved reagent control and response to ore characteristics.
 - Elution debottlenecking.
 - Carbon management and optimisation, inventory, acid wash, regeneration.
 - INCO circuit performance, reducing cyanide in process water
 - CCD wash efficiency, flow restrictions
 - Zn precip debottlenecking. New zinc feeders.

It does not stop, further work to achieve 90% Au and 70% Ag recovery.

- Circuit stability
 - Asset Management and increased MTBS
 - Feed blending for consistency
 - Control and response - Operator Training
- Further Enhance Gravity Recovery
 - Fluidisation water
 - Increased feed rate and second cyclone
 - Magnetic separator
 - GRG testing – what's possible on actual feed

- Flotation
 - Reagent automation and optimisation
 - Froth cameras and control improvement
 - Increasing mass pull
- Concentrate Leach/CCD
 - Oxygen addition improvements
 - Automate cyanide addition
 - Density control
 - Increase washing capacity
- CIL
 - Regeneration circuit optimisation and capacity
 - Additional Oxygen
 - Automate cyanide addition



Hidden Valley Mine

